



PSS LD / ZZ

Lifting Devices

PSS LD Lifting devices are designed for food industry operations for lifting and tipping of manipulation trolleys and plastic bigboxes. These devices significantly facilitate the handling of processed materials, which are

conveyed to individual machines and devices by them for further processing. The trolley or plastic bigbox filled with a material is pushed into the tipping fork that fast and easily conveys the material into a machine, where

it is further processed. PSS LD can be obtained in left or right hand design according to customer requirements and needs.

Basic options selection

- Mobile frame with 2 fixed and 2 rotary wheels (LD 350)
- Safety cage - height 2 000 mm (LD 350)
- Holder with a tray for frozen meat blocks (LD 350)
- Fixed tray for frozen meat blocks (instead of the fork) (LD 350)
- Fork for 120 l trolleys (LD 350)
- Fork for 200 l trolleys (LD 950)
- Special voltages and frequencies (standard: 3x400V - 50 Hz) (LD 950)
- Chute for the tipping fork
- Timer for automatic return
- Timer for automatic return including the stoppage 500 mm above the floor
- Automatic STOP before emptying



Advantages of lifting devices

- Lifting and tipping of manipulation trolleys and plastic bigboxes (LD 950)
- Easy and practical control by control buttons
- Safety sensor
- Safety cage (LD 950)
- Moving parts of the device are safely shielded
- Superior hygienic design characterized by closed column construction and polished surfaces

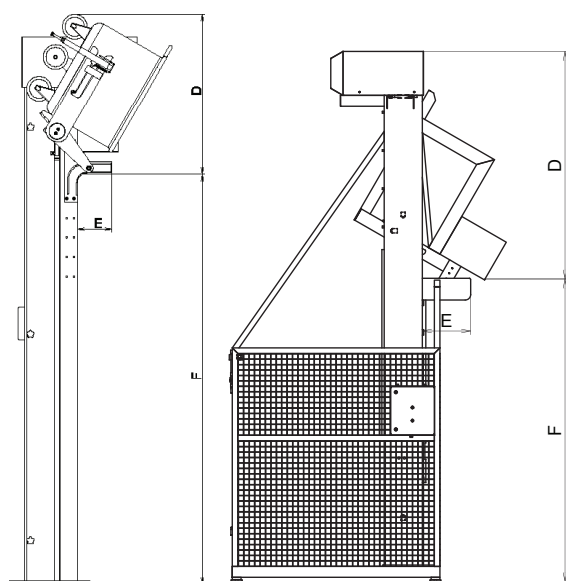

PARAMETER	PSS LD 350	PSS LD 950	
Input	0,75 kW	2,2 kW	
Tipping angle	35°	35°	
Lifting speed	3,5 m/min.	4,7 m/min.	
Capacity	350 kg	950 kg	
Weight of the device	350 kg (F 2225 mm)	1230 kg (F 4855 mm)	
	A	1 308 mm	2 520 mm
	B	938 mm	1 756 mm
	C	1 039 mm	1 780 mm
	D	988 mm	2 083 mm
	E	215 mm	441 mm
		1 170 – 1 650 mm	1 650 mm
Main dimensions		1 754 – 2 225 mm	2 150 mm
		2 070 – 2 550 mm	2 550 mm
	F	2 570 – 3 050 mm	3 050 mm
		3 070 – 3 550 mm	3 550 mm
		3 570 – 4 050 mm	4 050 mm
		4 070 – 4 550 mm	4 550 mm
		4 570 – 5 050 mm	5 050 mm

PARAMETER	PSS ZZ 2	PSS ZZ 4		
Input	1,1 kW	0,75 kW		
Tipping height	max. 1200 mm	max. 1250 mm		
Max. Allowed Load on Tipping Fork	260 kg	250 kg		
Weight of the device	180 kg	250 kg		
	A	1 300 mm	1 300 mm	
	B	900 mm	1 008 mm	
Main dimensions		C	1 830 mm	2 117 mm
		D	2 300 mm	2 607 mm

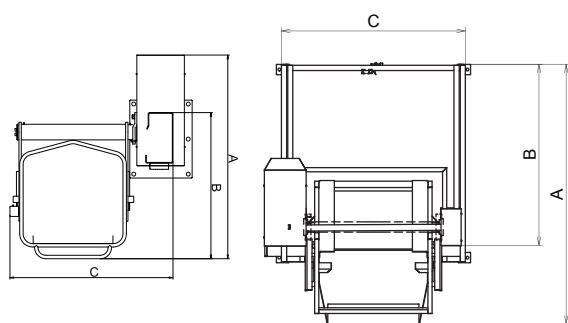

PSS LD 350

PSS LD 950

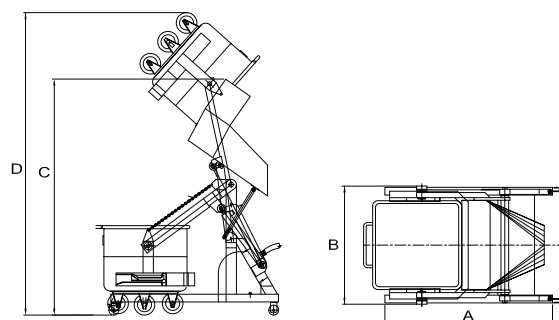

PSS ZZ

PSS SVIDNÍK, a.s.
Sovietských hrdinov 460/114
089 01 Svidník, Slovakia

tel.: +421/54/786 21 11
fax: +421/54/752 09 04

predaj@pss-svidnik.sk

www.pss-svidnik.sk



Notice:
As a result of continuous process improvement and modernization of our products there may be modifications and changes in characteristics and descriptions of machines. Therefore the manufacturer PSS SVIDNÍK, a.s. reserves the right to change any specifications and technical parameters of its products.

